

CAN-CBX-REL4

4 Relay Outputs

- 4 monostable relay outputs
- 2 change over contacts
- 2 normally open contacts
- CANopen

Relay Outputs

The CAN-CBX-REL4 is equipped with 4 relays which are electrically isolated from each other. Therefore various voltages can be applied to the CAN-CBX-REL4 module simultaneously.

Compact I/O Module

The CAN-CBX module series with In-Rail-Bus provides industry compatible CAN bus in-/output modules in combination with service-friendly 'wiring' of CAN bus and supply voltage.

In-Rail-Bus

The power supply and the CAN bus signals can be applied via the In-Rail-bus connector (TBUS-connector) integrated in the



mounting rail or separately via the clamp-connection.

From the In-Rail-Bus individual modules can be removed without interrupting the bus signals.

CAN Interface

The CAN interface is designed according to ISO11898 with electrical isolation and bit rates up to 1 Mbit/s.

The CANopen-node number and the CAN-bit rate can be easily set via coding switches.

LED Display

Four LEDs show the I/O-channel state and the CANopen node state.

Software Support

The module comes with CANopen firmware according to CiA-DS-301 and with a CANopen I/O-profile according to CiA-DS-401.

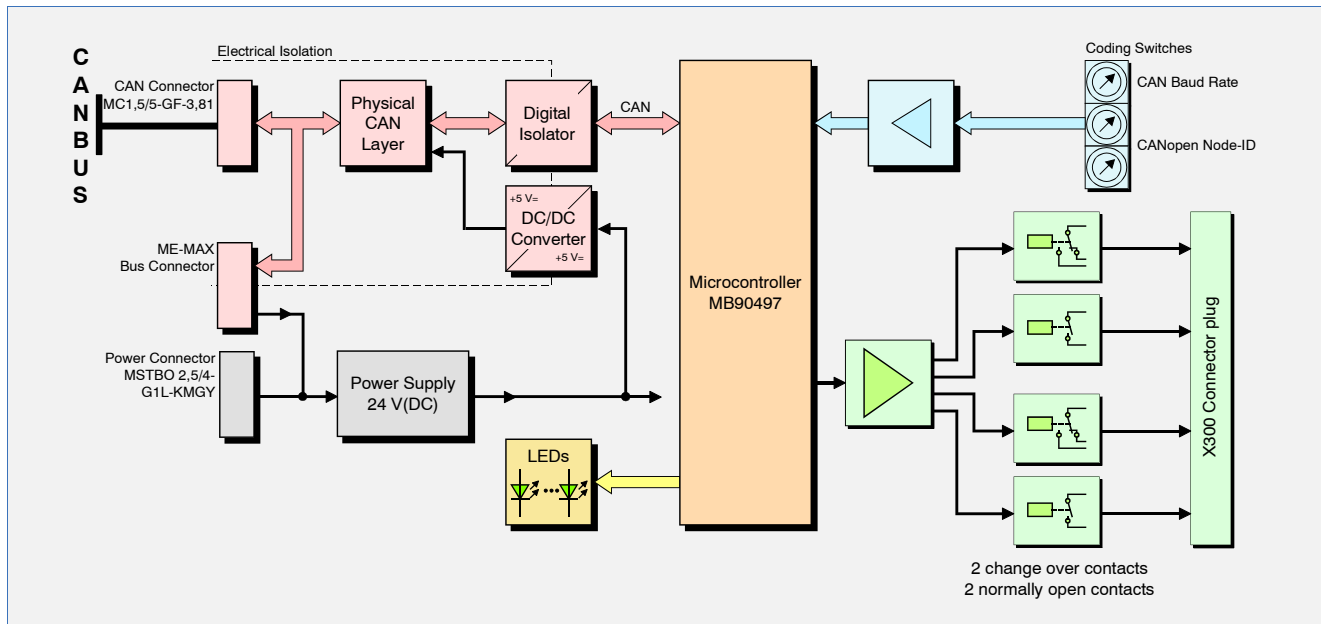

Technical Specifications:

Relay specification:	
Number of outputs:	4 outputs: 2x normally open, 2x change-over
Switching voltage:	max. 250 VAC, 125 VDC
Switching current:	max. 8 A (AC and DC)
Switching power:	max. resistive load: 2000 VA/240 W max. inductive load: 875 VA/170 W
Switching frequency:	max. 30 operations per minute
Endurance mechanical load:	100 000 cycles
CAN, Microcontroller:	
Microcontroller:	MB90F497, ISO 11898-1
CAN interface:	acc. to ISO 11898-2, differential, electrically isolated, bit rate up to 1 Mbit/s
Protocol:	CANopen DS-301, DS-401

General:	
Ambient temperature:	-20 °C ... +70 °C
Power supply:	nominal 24 VDC / 100 mA permitted range 18...30 VDC
Dimensions:	22 x 112 x 113 mm
Connectors:	Power: Phoenix MSTBO2,5/4-G1LKMGY CAN: Phoenix MC1,5/5-GF-3.81 I/O: Phoenix MC 1,5/10-G-5,08
Order information:	
Designation	order no.
CAN-CBX-REL4	4 relay outputs, including 1 CAN-CBX-TBUS (In-Rail-Bus connector, C.3000.01) C.3012.02