



# VME-PMC-CPU/2-CC

## PowerPC Processor Board with 2 PMC Slots Conduction Cooled

### Fully Equipped CPU

- Powerful VME-PCI bridge Tundra Tsi148
- 4-level VME arbiter and address space up to A64/D64
- VME64-extension connector
- Master or slave functionality
- High efficient PowerPC MPC8349, 533MHz
- 1 Gbit Ethernet port and 2 RS-232 serial ports with access via the front panel
- Add up to 2 PMC boards to your system
- One XMC according to VITA™ 42.3
- Featuring 2eVME and 2eSST fast protocol
- PCI 64 bit at 66 MHz, 3.3 V only

### Conduction Cooled Low Power Design

- Design for low power consumption and easy cooling
- Wide temperature range with conduction cooling
- Approved in many industrial applications
- Standard interfaces and form factors according to IEEE P1386-2001 and IEEE 1014 Rev. D
- PPMC according to VITA 32
- RTC buffered by ELDC or 5 V VMEbus Standby
- BSPs are available for VxWorks®, Linux® and QNX®

### ECC Memory Technology

- 512 Mbyte DDR2-RAM with Error Correcting Codes (ECC)
- 2 Gbyte NAND Flash allows even complex and ambitious operating systems as well as user's application
- 128 Mbyte Flash (NOR)
- XC3S1600E FPGA (shared with NAND Flash interface)

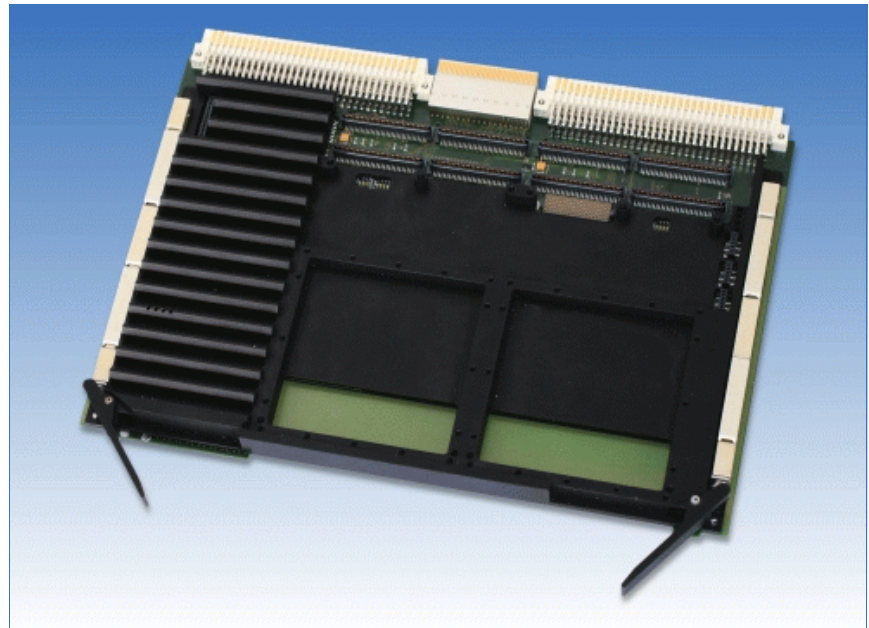

### VME-PCI Link

The VMEbus unit VME-PMC-CPU/2-CC is a VME64-base board which can carry up to two PMC modules of normal size.

For the VMEbus connection the VME-PCI bridge Tsi148 by Tundra is used.

### VMEbus Interface

The Tsi148 is designed in a way that the board can either operate as slave or as master on the VMEbus. If the board operates as master, it supports a 4-level arbiter.

The VMEbus interrupt can be applied to any of the seven interrupt-request lines. The board is connected to the VMEbus by two 160-pin VG-connectors (complementary to DIN41612) for VME64 systems.

### PowerPC CPU

A high efficient PowerPC MPC8349 powers the board at 533 MHz with the advantage of a frugal power consumption. The fast floating point unit of type 603 allows complex algorithms at formidable speed. The memory enables ECC with a capacity of 512 Mbyte DDR2-typed RAM. The flash memory of 2 Gbyte allows even complex and ambitious operating systems as well as user's application.

The on-board FPGA controls the NAND flash devices, but is mighty enough to enable the usage for user logic. The usage of the esd CAN core (esdACC) is possible too (via P0 I/O).

Furthermore the board comes with 1 Gbit Ethernet port and 2 RS-232 serial ports with access via P0 rear I/O pins.

### PMC Slots

Both PMC slots are designed according to the standard IEEE Std 1386-2001 (except the standard I/O pin routing). It is possible therefore to insert all PMC modules, that use 3.3 V signalling only.

In addition to the connectors for the PMC-address/data and control signals, every slot of the VME-PMC-CPU/2 has an I/O-connector which applies the I/O-signals of the PMC modules to VMEbus connector P2. Two different P2 pin assignments are available: In the standard configuration each P2-pin is only connected to one I/O-pin of the PMC-modules acc. to VITA 35 (P4V2-64ac, P4V0-64).

In the option '32P' the pin assignment is acc. to IEEE Std 1386-2001, Table 8. This pin assignment offers the connection of the two PMC-modules via P2, because several PMC-I/O-signals are shorted at P2.

### Software

BSPs are available for VxWorks, Linux and QNX.

### Options

An optional 1 Gbyte DDR2-typed RAM is available. Please, contact our sales-team (sales@esd.eu) for further information.

# VME-PMC-CPU/2-CC

PowerPC Processor Board with 2 PMC Slots Conduction Cooled

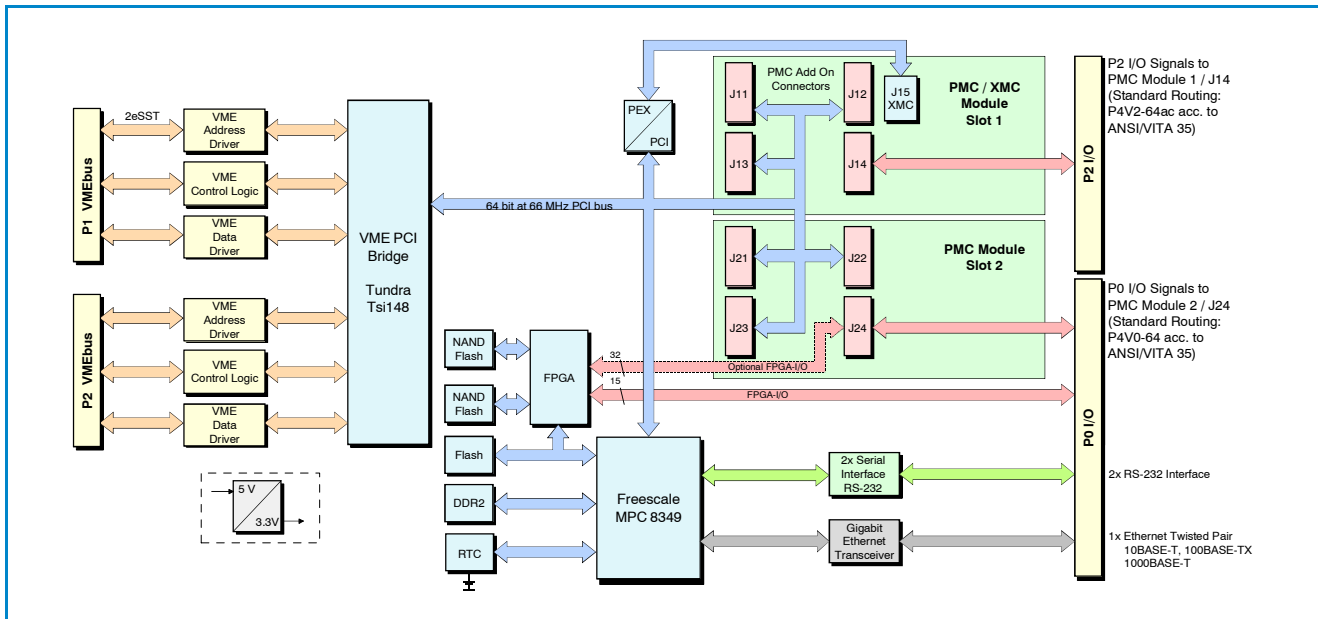

## Technical Specifications:

<b>VMEbus:</b>	
Controller	TUNDRA Tsi148
VMEbus access	- Legacy protocols to protect existing VME investment - VME64 extensions - 2eVME and 2eSST protocols
Base address	Geographical addressing
Address modifier	Standard supervisory and nonprivileged data access, extended supervisory and non-privileged data access, short supervisory and nonprivileged access
VMEbus standard	IEEE 1014 Rev. D
VMEbus connector	160-pole VG connector (complementary to DIN 41612), acc. to VME64 extension std.
<b>PMC/XMC Slots:</b>	
Standard	IEEE Std 1386-2001
Size	Two single size modules
VME PCI Bridge	Tundra Tsi148, 32/64 bit at 33/66 MHz
PCI Voltage level	3.3 V (signal level) only
XMC	Slot 1 with 4 lane XMC interface (J15) according to VITA 42.3 standard
Voltage option	On-board 3.3V generation
<b>PowerPC CPU:</b>	
Microcontroller	Freescale MPC 8349, 533 MHz
Memory	512 Mbyte DDR2 RAM ECC, 128 Mbyte Flash (NOR), 2 Gbyte NAND Flash,
FPGA	XC3S1600E (shared w. NAND Flash interface)
<b>Interfaces:</b>	
Serial interface	2x RS-232 via P0
Ethernet	1x Ethernet Twisted Pair, 1000BASE-T, via P0

<b>General:</b>	
Temperature	-40...+75 /C
Humidity	Max. 90 %, non-condensing
Connector types	P1, P2: VMEbus (160 pins) P0: VMEbus (114 pins) J11, J12, J21, J22: PMC address/data J13, J23: PCI 64 signals J14, J24: PMC I/O signals J15: XMC
Board size	160 mm x 233 mm
VME dimensions	6 U height, 4 HP width

<b>Order information:</b>		
<b>Hardware</b>		<b>Order No.</b>
VME-PMC-CPU/2-CC	VMEbus base board for two single PMC modules, P2-pin assignment acc. to VITA 35 (P4V2-64ac, P4V0-64), (no interconnection between PMC modules), conduction cooled, extended temperature range: -40...+75 /C	V.1917.03
VME-PMC-CPU/2-CC-32P2	VMEbus base board for two single PMC modules, P2-pin assignment acc. to IEEE Std 1386-2001, Table 8 (interconnection between 16 pins of the PMC-modules), conduction cooled, extended temperature range: -40...+75 /C	V.1917.14
<b>Software Support</b>		
VME-PMC-CPU/2-Linux	Linux BSP	V.1917.57
VME-PMC-CPU/2-VxWorks	VxWorks BSP	V.1917.58
<b>Manuals</b>		
VME-PMC-CPU/2-ME	English user manual	V.1917.21